



AFE45 | Face Mill

Q max High Efficient	Jet Air Hole	▽ Roughing	▽▽ Semi-Finishing	HRC 60	No. of Teeth 4-14
--------------------------------	------------------------	----------------------	-----------------------------	------------------	-----------------------------

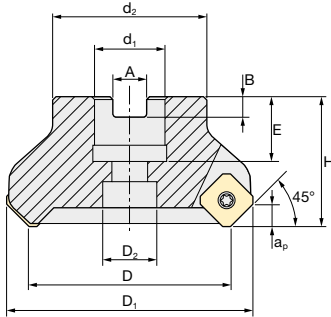

Fig. 1

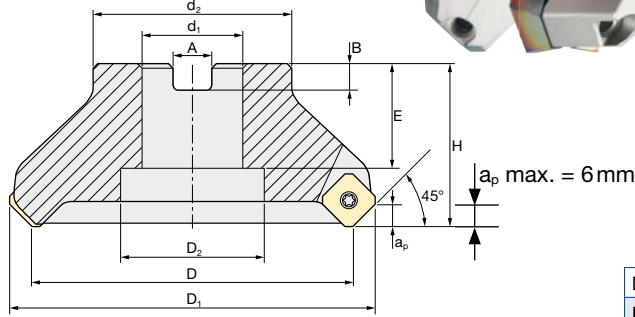

Fig. 2

Diameter Holder only [mm]	
D50-80 mm	0/-0.2 mm
D100-125 mm	0/-0.3 mm
D160-250 mm	0/-0.4 mm

ID Code	Item Code	Z	D	D ₁	d ₁	D ₂	d ₂	A	B	H	E	a _p	Carbide Seat	Coolant hole	Fig.
FH193	AFE45-4050R-4-UE	4	50	63.4	22	18	48	10.4	6.3	40	20	6	-	•	1
FH194	AFE45-4050R-5-E	5													
FH195	AFE45-4063R-5-UE	5	63	76.6	22	18	48	10.4	6.3	40	20	6	-	•	1
FH196	AFE45-4063R-6-E	6													
FH198	AFE45-4080R-6-UE	6	80	93.5	27	20	58	12.4	7	50	22	6	-	•	2
FH199	AFE45-4080R-8-E	8													
FH201	AFE45-4100R-7-UE	7	100	113.5	32	26.5	78	14.4	8	50	25	6	-	•	2
FH202	AFE45-4100R-9-E	9													
FH204	AFE45-4125R-8-UE	8	125	138.5	40	32.5	90	16.4	9	63	29	6	-	•	2
FH205	AFE45-4125R-10-E	10													
FH206	AFE45-4160R-9-UE	9	160	173.5	40	56	114	16.4	9	63	29	6	-	•	2
FH207	AFE45-4160R-11-E	11													
FH208	AFE45-4200R-10-UE	10	200	213.5	60*	61	145	25.7	14	63	39	6	-	•	2
FH209	AFE45-4200R-12-E	12													
FH210	AFE45-4250R-14-E	14	250	263.4			160								

* + Screws

Inserts
SE..T13T3AGTN
SEET13T3AG..N-S

	Parts	Screw				Wrench (15IP)			
		Type	ID Code	Item Code	Fastening Torque [Nm]	ID Code	Item Code		
		D 50-80	ET062	242-143 Short	3 Nm	ET061	490-150		
	Parts	Screw				Wrench (15IP)			
		Type	ID Code	Item Code	Fastening Torque [Nm]	ID Code	Item Code		
		D 100-250	ET060	242-143	3 Nm	ET061	490-150		
	Parts	Carbide Seat		Screw for Seat		Wrench for Seat (H3.5)			
		Type	ID Code	Item Code	ID Code	Item Code	Fastening Torque [Nm]	ID Code	Item Code
		D 100-250	ET058	212-271	ET059	212-280	5 Nm	ET057	100-230

※ The seat must be installed so that the surface indicated by ※ is facing the outside of the cutter.

* In consideration of reducing environmental loads, the screwdriver and wrench for seat are now sold separately to avoid sending unnecessary duplicate tools. We hope you will understand our reasoning.



INSERTS AFE45 | Face Mill AFE45 Type

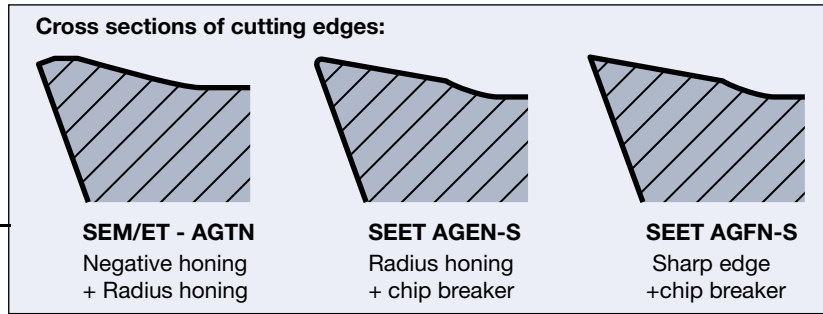
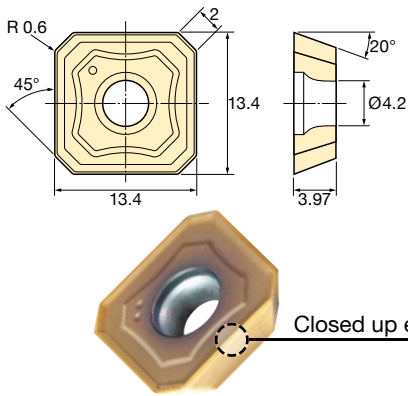

		Target Hardness of Workpiece							
		Soft Hard							
		Grade							
		SD5010	GX2140	JM4060	JS4045	JS4060	JP4020	JP4005	
Grade Info		Aluminium	Mild steel Cast iron	SUS	General steel	Mild steel	Hardened steel Cast iron SUS	Hardened steel	
Coolant		Emulsion Mist Air-blow	Air-blow	Emulsion Mist Air-blow	Air-blow	Emulsion Mist Air-blow	Emulsion Mist Air-blow	Emulsion Mist Air-blow	
Item Code		Tolerance Class	Target hardness		ID Code				
SEMT13T3AGTN	M	Negative honing + chip breaker	WF250		WF251	WF220	WF219		
SEET13T3AGTN	E	Negative honing + chip breaker	WF246	WF247	WF249	WF218	WF217	WF248	
SEET13T3AGEN-S	E	Radius honing + chip breaker		WF244	WF245		WF215		
SEET13T3AGFN-S	E	Sharp edge + chip breaker	WF216						

SD5010: DLC coated grade for Aluminium

