

MORSA AUTOMATICA AUTOCENTRANTE / SELF-CENTERING AUTOMATIC VISE

**IDEALE PER
CENTRI A 5 ASSI**
**IDEAL FOR 5 AXIS
MACHINING CENTRES**



**PNEUMATICA A DOPPIO
EFFETTO O IDRAULICA**
**PNEUMATIC DOUBLE EFFECT
OR HYDRAULIC**

**AUTOMATIC
CONTROL**

**5 AXIS
MACHINE**

**AIR or OIL
DIRECT INPUT**

Art.670

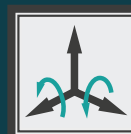
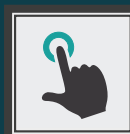
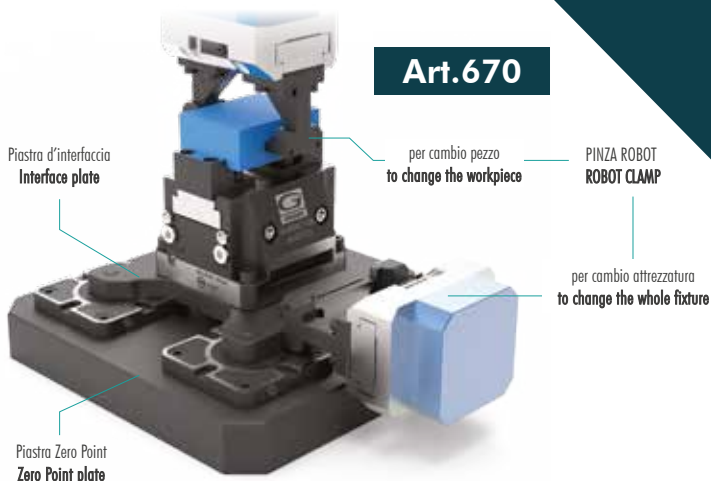

Come le altre morse della serie Multitasking le **GripMatic** Art. 670 sono nate espressamente per i centri a 5 assi, in modo da permettere la lavorazione su 5 facce mantenendo tolleranze ristrette ed elevata rigidità. Il loro funzionamento idraulico o pneumatico, grazie ad un pistone a doppio effetto garantisce una completa gestione in automatico delle morse. La notevole modularità permette inoltre di utilizzarle su qualunque tipologia di macchina e grazie alla predisposizione e la completa gestione tramite CNC, si ha la possibilità di automatizzare i processi di serraggio incrementando così la produttività della vostra officina.

As all the other vises of the Multitasking Series, **GripMatic** series Art.670 is conceived for 5-axis machining centers in order to work on 5 surfaces always respecting the tight tolerances and the high rigidity. The activation is made by the oil or compressed air through a double effect piston that grants the complete managing of the vise. One of the main features is modularity that allows this kind of vise to be used on any type of machine and, thanks to its configuration and complete handling by CNC, it is also possible to automate the clamping process so increasing the productivity of your company.



Ganascia mobile lavorabile
Soft movable jaw

Esempio 1



Ganascia mobile lavorabile ridotta
Soft narrow movable jaw

Esempio 2



Ganascia mobile a gradino con piastre ad inserti Grip
Step movable jaw with Grip jaw plates

Esempio 3

MORSA AUTOCENTRANTE CON GANASCE MOBILI LAVORABILI

SELF-CENTERING VISE WITH SOFT MOVABLE JAWS

Tipo (grandezza) morsa / Vise (type) size

Art. 670

Corsa / Stroke →

Morsa autocentrante pneumatica o idraulica con ganasce mobili lavorabili

Self-centering pneumatic or hydraulic vise with soft movable jaws



		2 PN 7 / ID 19	3 PN 14,4 / ID 37,5	4 PN 16,9 / ID 47
kN	A	6,4	8,5	12
	A1	88,9	130,2	162
	B	25	30	35
	C	80	105	130
	D	108	166	206
	E	52	78	95
	G	10	12	16
	H	90	140	170
	W	74	99	124
kg		6,7	20	38
	Cod	7.67.0PN20	7.67.0PN30	7.67.0PN40
	Cod	7.67.0ID20	7.67.0ID30	7.67.0ID40

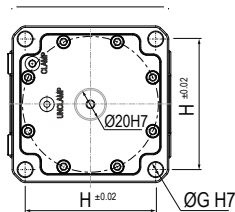
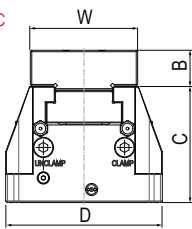
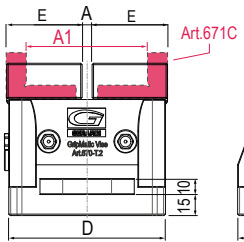

La morsa GripMatic Art.670 pneumatica permette di ottenere parametri di serraggio notevolmente superiori rispetto ad un normale funzionamento pneumatico grazie alle molle per stampi all'interno. Questo sistema garantisce una maggior sicurezza in caso di perdita di pressione evitando il mancato serraggio del pezzo e conseguenti pericoli di lesione alle attrezzature e al personale.

Thanks to the internal mold springs, Art.670 GripMatic pneumatic vise allows to obtain better clamping parameters, in respect to the normal functioning. This system guarantees a higher safety level as it clamps the workpiece even in case of pressure loss and so avoiding fixtures damages and workers injuries

MORSA PNEUMATICA

PNEUMATIC VISE



Art.670PN

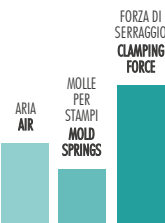

Aria - Air

Pneumatic	Type 2	Type 3	Type 4
Air Pressure Input (bar)	Clamping Force (kN)	Clamping Force (kN)	Clamping Force (kN)
7	5,6	10,7	11,4
8	6,1	12,3	13,3
9	6,6	13,2	14,6
10	7	14,4	16,9

Utilizzare il moltiplicatore di pressione aria Art.408 per incrementare la pressione
To increase the air pressure use the multiplier Art.408

MORSA IDRAULICA

HYDRAULIC VISE



Art.670ID

DISPONIBILI ANCHE
60 o 350 BAR
ALSO AVAILABLE
60 or 350 BAR



Olio - Oil

Hydraulic	Type 2	Type 3	Type 4
Oil Pressure Input (bar)	Clamping Force (kN)	Clamping Force (kN)	Clamping Force (kN)
10	5,8	15	-
15	8,5	21	27
20	11,7	27	38
25	14,5	33,5	47
30	17	37,5	-

Alcuni fattori, come la lubrificazione, lo staffaggio, gli attriti ed altro, possono modificare i valori indicati fino a ±10%
Some factor as lubrication, clamping on the machine table, frictions and more can modify above values within a ±10%

NON SUPERARE I VALORI INDICATI NEL GRAFICO - DO NOT EXCEED CHART VALUES

T.2

ARIA - AIR OLIO - OIL

Valore massimo consigliato - Max suggested value

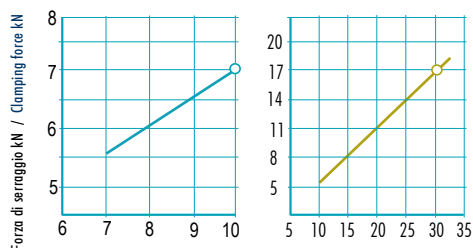

Pressione uscita aria o olio (bar) - Air or Oil outlet pressure (bar) 1 bar = 14,5 psi
Pressione minima apertura (bar) - Min. pressure opening jaw (bar) = 6 bar

T.3

ARIA - AIR OLIO - OIL

Valore massimo consigliato - Max suggested value

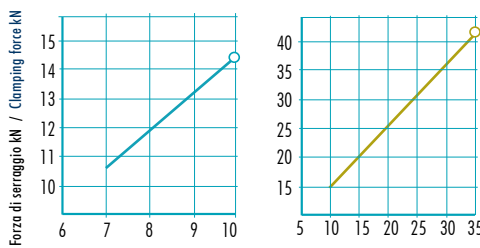

Pressione uscita aria o olio (bar) - Air or Oil outlet pressure (bar) 1 bar = 14,5 psi
Pressione minima apertura (bar) - Min. pressure opening jaw (bar) = 5 bar

T.4

ARIA - AIR OLIO - OIL

Valore massimo consigliato - Max suggested value

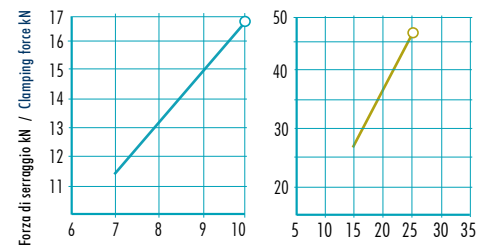

Pressione uscita aria o olio (bar) - Air or Oil outlet pressure (bar) 1 bar = 14,5 psi
Pressione minima apertura (bar) - Min. pressure opening jaw (bar) = 5 bar

PIASTRA DI INTERFACCIA PER MORSE GRIPMATIC INTERFACED PLATS FOR GRIPMATIC VISES



Art. 670CP

Piastra di interfaccia per morse Grip Matic Art.670 PN semiautomatica con innesto aria tramite attacco rapido e gestione del sistema manuale tramite selettore

Interface plate for GripMatic vise Art.670PN - semi-automatic quick coupling air input and manual system control through a selector.

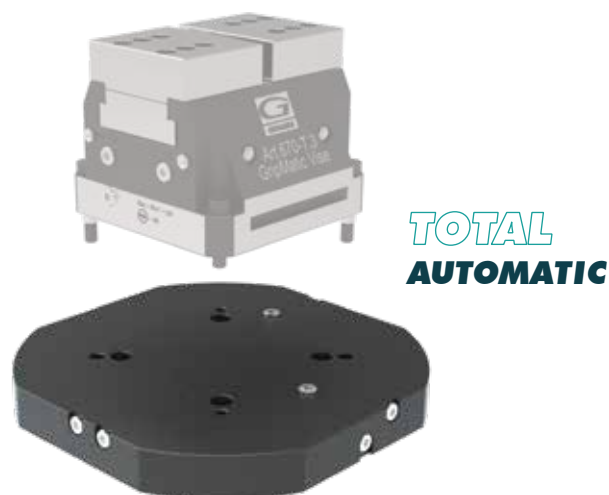

Art. 670AP

Piastra di interfaccia per morse Grip Matic Art.670PN automatica con innesto aria diretto tramite la tavola della macchina e gestibile direttamente dal CNC. Piastra completamente personalizzabile in base alle funzionalità della macchina utensile (comando di presenza pezzo e pulizia)

Interface plate for GripMatic vise Art.670PN - automatic with air input through the machine table and possible to control directly by the CNC. This plate can be fully tailored according to the characteristics of the machine (workpiece positioning check and cleanliness).

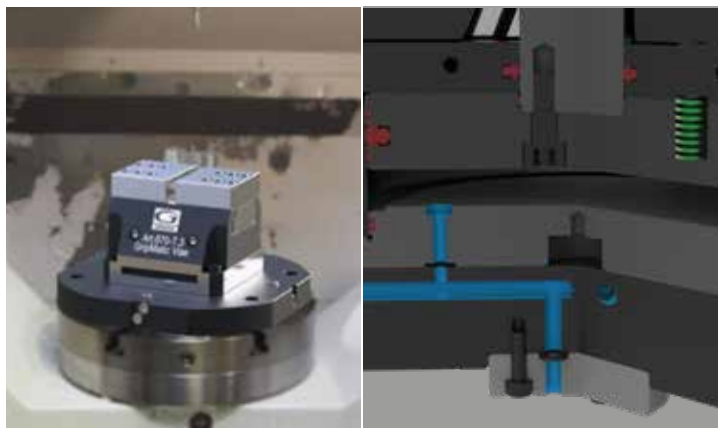

Nata espressamente per i centri a 5 assi, la gamma GripMatic permette di intervenire sulle 5 facce del particolare in lavorazione con riferimenti precisi in spazi contenuti garantendo usure inesistenti e grande rigidità.
Adduzione Aria o Olio sia laterale che inferiore.

- ✓ *Idrraulica o pneumatica. Possibilità di gestire l'apertura e la chiusura mediante aria compressa o olio*
- ✓ *Predisposizione faccia inferiore per permettere l'adduzione di aria o olio compressa mediante piastra d'interfaccia direttamente dalla tavola della macchina.*
- ✓ *Tre guide interne con trattamento antiattrito per la massima scorrevolezza*
- ✓ *E' presente la sede per l'applicazione di un sensore di prossimità per la corretta gestione degli automatismi.*
- ✓ *Ganasce dolci lavorabili, ganasce ridotte lavorabili e ganasce predisposte per l'utilizzo di piastre ganasce specifiche (liscia, rigata, grip...)*
- ✓ *Sono presenti carter di copertura contro l'intrusione di trucioli.*

Designed for 5 axis machines, GripMatic series of vises allow machining operations on the 5 workpieces sides with perfect alignment in a space saving design, extremely high wear resistance, with reduced deflection.
Air or oil input both lateral and lower.

- ✓ *Possibility to manage the opening/closing by compressed air or oil*
- ✓ *Configuration of the lower surface to allow the addition of the compressed air or oil through an interface plate directly from the machine spindle*
- ✓ *High level of sliding of the internal rails ensured thanks to an anti-friction treatment and specific lubricants always for max performances also with pneumatic use.*
- ✓ *It is possible to apply a proximity detector for the correct handling of the automatisms.*
- ✓ *Soft workable jaws, narrow-width workable jaws, jaws configured for the use of specific jaw plates (smooth, grip, serrated...)*
- ✓ *The vise is equipped with covering carters that shelter the item from chips.*



GANASCE & PIASTRE GANASCE PER MORSE GRIPMATIC

JAWS & JAW PLATES FOR GRIPMATIC VISES

Ganasce GripMatic - GripMatic Jaws

Art. 671A

Ganascia mobile lavorabile
Soft machineable movable jaw

Non Temprato - Not Hardened



Example 1

Art. 671B

Ganascia mobile lavorabile ridotta
Soft machineable narrow movable jaw

Non Temprato - Not Hardened



Example 2

Art. 671C

Ganascia mobile lavorabile predisposta
per piastre ganasce standard
Soft machineable movable jaw for
width standard jaw plates

Non Temprato - Not Hardened



Example 3



Art. 243

Piastra piana rigata
Grooved straight plate



Art. 245

Piastra piana liscia
Smooth straight jaw plate



Art. 247G

Piastra piana con inserti GRIP
Straight plate with GRIP inserts

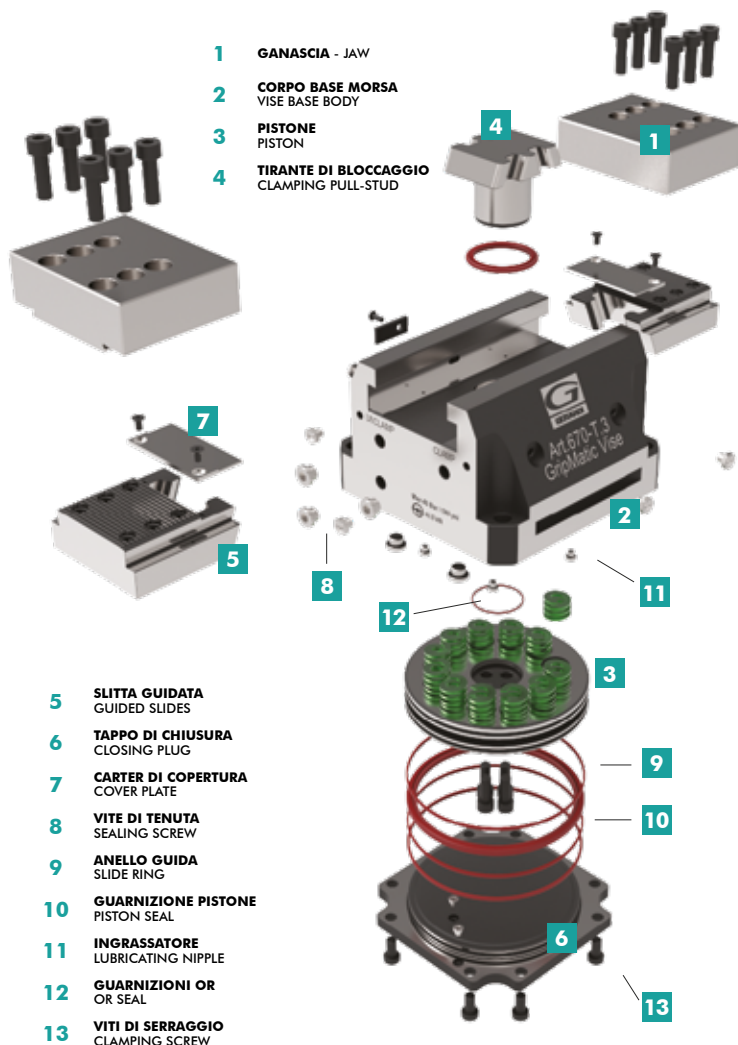

1 GANASCIA - JAW

2 CORPO BASE MORSA
VISE BASE BODY

3 PISTONE
PISTON

4 TIRANTE DI BLOCCAGGIO
CLAMPING PULL-STUD

5 SLITTA GUIDATA
GUIDED SLIDES

6 TAPPO DI CHIUSURA
CLOSING PLUG

7 CARTER DI COPERTURA
COVER PLATE

8 VITE DI TENUTA
SEALING SCREW

9 ANELLO GUIDA
SLIDE RING

10 GUARNIZIONE PISTONE
PISTON SEAL

11 INGRASSATORE
LUBRICATING NIPPLE

12 GUARNIZIONI OR
OR SEAL

13 VITI DI SERRAGGIO
CLAMPING SCREW



Automatic vise

- ✓ Utilizzo non presidiato
- ✓ Comandabile dal CNC
- ✓ Ideale per carico e scarico tramite robot
- ✓ Unattended use possible
- ✓ CNC manageable
- ✓ Ideal for automatic workpiece loading by robot



Air or oil direct input

Adduzione di aria compressa o olio direttamente dalla tavola della macchina

Compressed air or oil addition directly from the machine table.



Zero-Point Ready

Predisposizione per il posizionamento rapido e preciso della morsa GripMatic tramite piastra Zero Point

Set-up for the quick and safe positioning of the GripMatic vise through Zero Point plate.

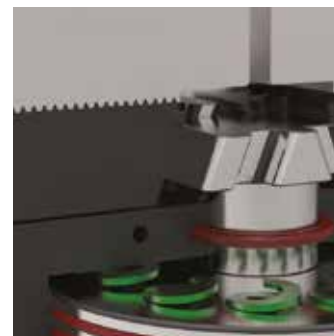

Clamping FORCE

	PN	ID
T.2	7 kN	19 kN
T.3	14,4 kN	37,5 kN
T.4	16,9 kN	47 kN