

GrooVical

Precise Grooving & Turning Applications



METRIC

GrooVical

Precise Grooving & Turning Applications

CONTENTS:

■ Technical Data	Page 3
■ GrooVical Inserts & Ordering Code	Page 5
■ GrooVical Toolholders & Ordering Code	Page 11

New Range of Indexable Grooving Inserts

The **Groovical** family of products by Groovex offers improved solutions for internal and external grooving and turning applications. GVN26 and GV29 feature inserts with three cutting corners and a unique rigid clamping system for improved productivity.

The new GVN style inserts offer new applications in the Groovical line, including Turning and Grooving chip former to form helical chips, spiral chips for grooving, new parting off inserts, machining close to shoulders and left hand toolholders.

GVN26 t_{max} = Groove Depths up to 5.5mm

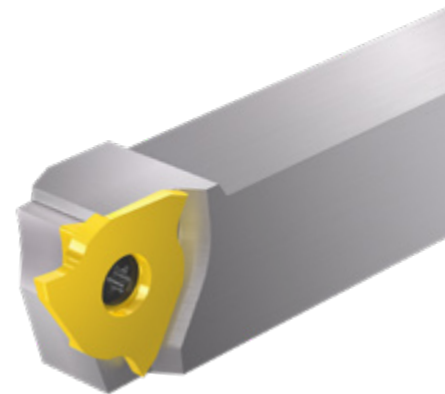
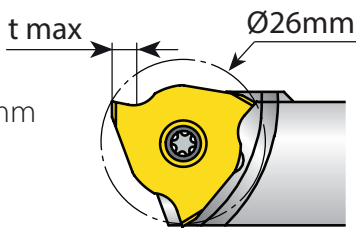

W = Groove Widths from 0.5-2.5mm

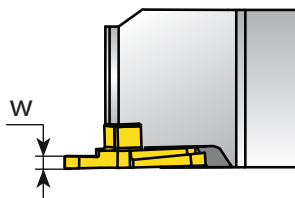

GVN29 t_{max} = Groove Depths up to 6.5mm

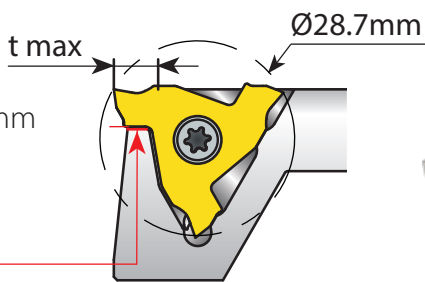

Additional Corner Support

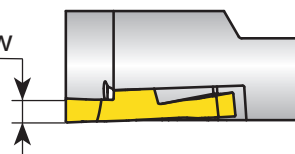

Groovical Technical Data

Recommended Grades and Cutting Data

Material Group	Vargus No.	Material	Hardness Brinell HB	Vc [m/min]	
				Coated	
				VKX	
P Steel	1	Unalloyed Steel	Low Carbon (C=0.1-0.25%)	125	140-200
	2		Medium Carbon (C=0.25-0.55%)	150	120-180
	3		High Carbon (C=0.55-0.85%)	170	110-180
	4	Low Alloy Steel (alloying elements≤5%)	Non Hardened	180	100-155
	5		Hardened	275	110-180
	6		Hardened	350	80-135
	7	High Alloy Steel (alloying elements>5%)	Annealed	200	70-115
	8		Hardened	325	50-100
	9	Cast Steel	Low Alloy (alloying elements <5%)	200	30-50
	10		High Alloy (alloying elements >5%)	225	20-40
M Stainless Steel	11	Stainless Steel Ferritic	Non Hardened	200	70-120
	12		Hardened	330	60-95
	13	Stainless Steel Austenitic	Austenitic	180	70-120
	14		Super Austenitic	200	40-90
	15	Stainless Steel Cast Ferritic	Non Hardened	200	80-110
	16	Stainless Steel Cast Austenitic	Hardened	330	65-110
	17		Austenitic	200	85-100
	18	Hardened	330	60-100	
K Cast Iron	28	Malleable Cast Iron	Ferritic (short chips)	130	70-120
	29		Pearlitic (long chips)	230	70-120
	30	Grey Cast Iron	Low Tensile Strength	180	70-120
	31		High Tensile Strength	260	60-100
	32	Nodular Sg Iron	Ferritic	160	50-80
	33		Pearlitic	260	60-90
N(K) Non-Ferrous Metals	34	Aluminium Alloys Wrought	Non Aging	60	100-240
	35		Aged	100	80-170
	36	Aluminium Alloys Cast	Cast	75	100-150
	37		Cast & Aged	90	80-120
	38	Aluminium Alloys Cast Si 13-22%	Cast Si 13-22%	130	100-150
	39	Copper and Copper Alloys	Brass	90	80-200
	40		Bronze And Non Leaded Copper	100	80-200
	S(M) Heat Resistant Material	19	High Temperature Alloys	Annealed (iron based)	200
20		Aged (iron based)		280	35-50
21		Annealed (nickel or cobalt based)		250	20-30
22		Aged (nickel or cobalt based)		350	15-25
23		Titanium Alloys	Pure 99.5 Ti	400Rm	140-170
24			α+β Alloys	1050Rm	50-70
H(K) Hardened Material	25	Extra Hard Steel	Hardened & Tempered	45-50HRc	45-60
	26			51-55HRc	40-50

! The maximum recommended **feed rate** is one-tenth of the insert width (W).

! The minimum recommended **depth of cut** is twice the corner radius (r).

VTX

Excellent for Grooving applications in medium-to-high cutting speeds and in dry conditions. Multi-layered AlTiN coated, general purpose grade for prevention of peeling and chipping.

* For **VTX Grade**, increase speed by 20%.

VKX

Standard grade for grooving applications. Single-layered AlTiN+TiN coated.

Recommended Feed Rate for Grooving & Turning Finishing Operations

Insert Width (mm)	High Alloy Steel, 330 HB, 2100 Kc [N/mm ²]		Austenitic Stainless Steel, 200 HB, 2600 Kc [N/mm ²]	
	Depth ap = Insert Width x variable	Average f mm/rev	Depth ap = Insert Width x variable	Average f mm/rev
0.4 mm - 0.9 mm	0.055	0.04	0.035	0.02
1.0mm - 1.5mm	0.055	0.07	0.035	0.04
1.6 mm - 2.0 mm	0.060	0.11	0.040	0.07
2.1 mm - 2.5 mm	0.060	0.14	0.040	0.09
2.6 mm - 3.0 mm	0.060	0.17	0.040	0.11
3.1 mm - 4.0mm	0.060	0.21	0.040	0.14
4.1 mm - 5.5 mm	0.060	0.28	0.040	0.19

| The above recommendations are for achieving a stable and recurring tool life.

| Exceeding higher feed rates may cause excessive wear and breakage.

D max Limitations

GVN26 External - Depth of Groove in Relation to Workpiece Dia.

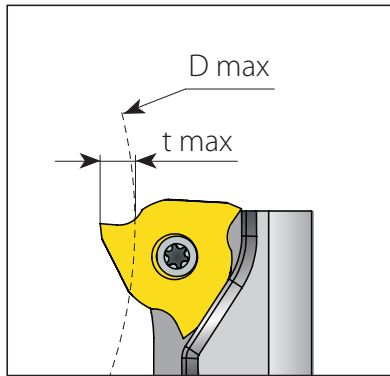

D max is 150mm

GV29 / GVN29 External - Depth of Groove in Relation to Workpiece Dia.

Dimensions mm	
t max	D max
0.5	1085.0
1	590.0
1.5	408.0
2	310.0
2.5	250.0
3	210.0
3.5	180.0
4	160.0
4.5	145.0
5	130.0
5.5	120.0
6	110.0
6.5	105.0

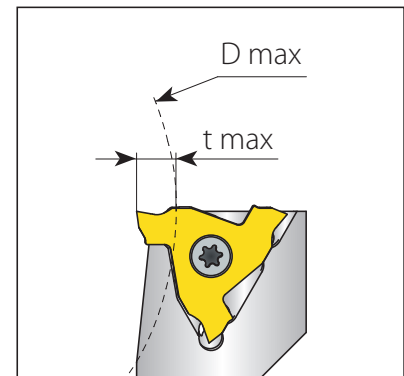

D min Limitations

GV29 / GVN29 Internal - Depth of Groove in Relation to Bore Dia.

Dimensions mm	
t max	D min
0.5	41.8
1	42.3
1.5	42.8
2	43.5
2.5	44.2
3	45.1
3.5	46.1
4.0	47.2
4.5	48.3
5.0	49.9
5.5	54.2
6.0	73.5
6.5	104.5

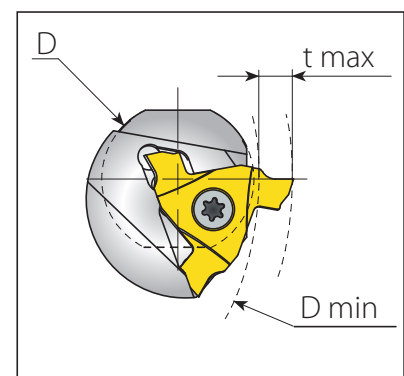

GrooVical Inserts

Close to Shoulder (GVN) Inserts:

Super Positive Rake Grooving.....	6
Turning & Grooving Chip Former.....	6
Square Grooving.....	7
Round Grooving.....	8
Parting Off.....	9

GV29 Neutral Inserts:

Square Grooving.....	10
Round Grooving.....	10

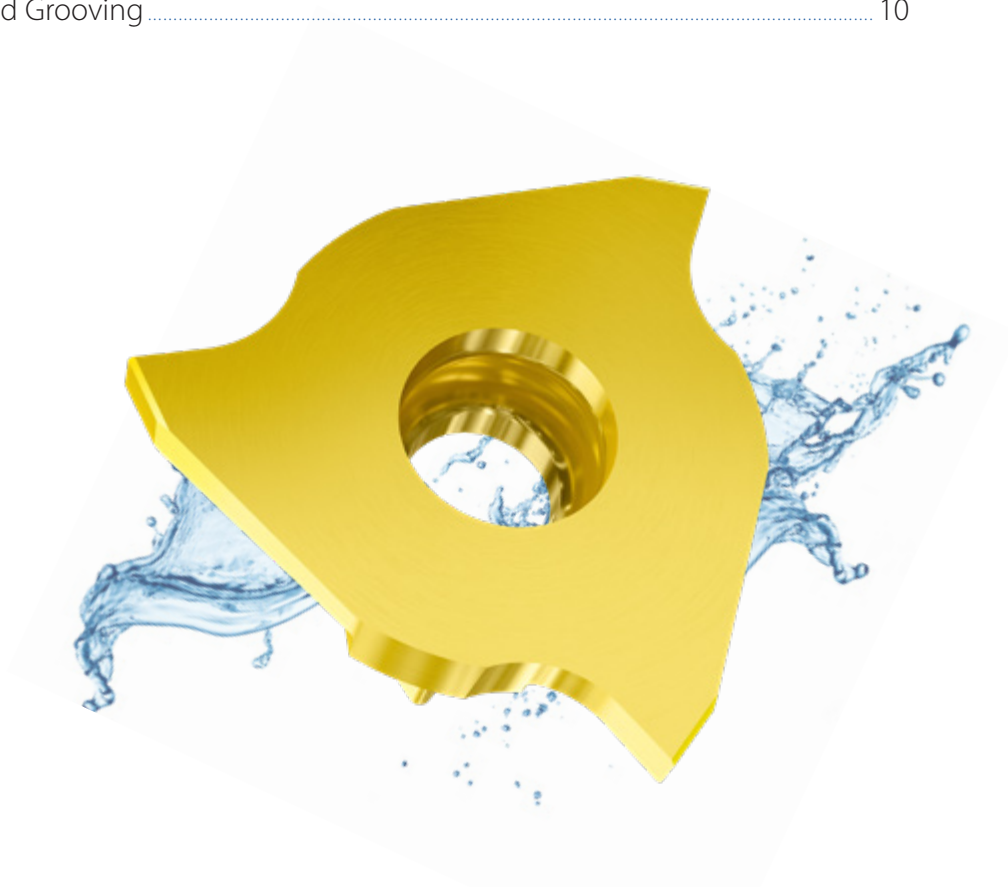

GrooVical Inserts Ordering Code System

GVN	26	R	P	0.5	-	0.05	-	15	R	VKX
1	2	3	4	5		6		7	8	9
1 - Insert Type		2 - Circular Circumference		3 - RH or LH		4 - Type of Application		5 - Grooving Width		
GV - Groovical Neutral GVN - Groovical Close to Shoulder		26 - 26mm 29 - 28.7mm		R - RH L - LH N - RH/LH		T - Turning & Grooving S - Square Grooving SP - Positive Rake Grooving R - Round Grooving P - Parting Off X - Special Profile		0.5 to 6.35mm		
7 - Approach Angle		8 - Cutting Side		9 - Carbide Grade		6 - Corner Radius				
6 - 6 Deg. 15 - 15 Deg.		R - Right corner leading L - Left corner leading None - Neutral		VTX, VKX		0.0 - 1mm				

Close to Shoulder **Super Positive Rake Grooving (SP)**

NEW

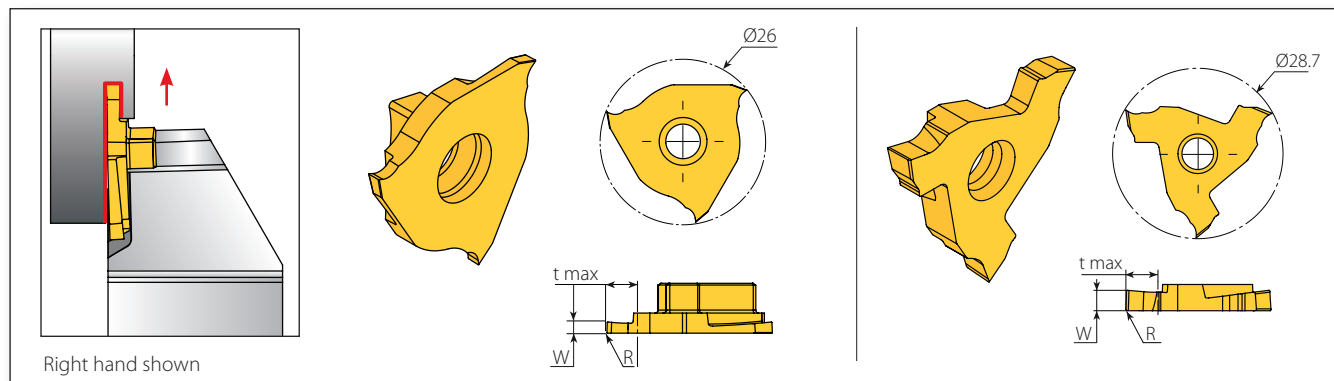

Insert Size	Ordering Code	Dimensions mm			Grade		Toolholder
		W \pm 0.02	R \pm 0.03	t max	VKX	VTX	
26	GVN26R/LSP1.0-0.08	1.0	0.08	2.25	◦	•	GVNE...-26, GVNE90...-26
	GVN26R/LSP1.5-0.08	1.5	0.08	3.00	◦	•	
	GVN26R/LSP2.0-0.1	2.0	0.10	3.75	◦	•	
	GVN26R/LSP2.5-0.15	2.5	0.15	3.75	◦	•	
29	GVN29R/LSP3.0-0.2	3.0	0.20	4.90	◦	•	GVNE...-29-1, GVNE90...-29-2, GVNI...-29

◼ • In stock ◦ Available upon request

Close to Shoulder **Square Turning & Grooving Chip Former**

NEW

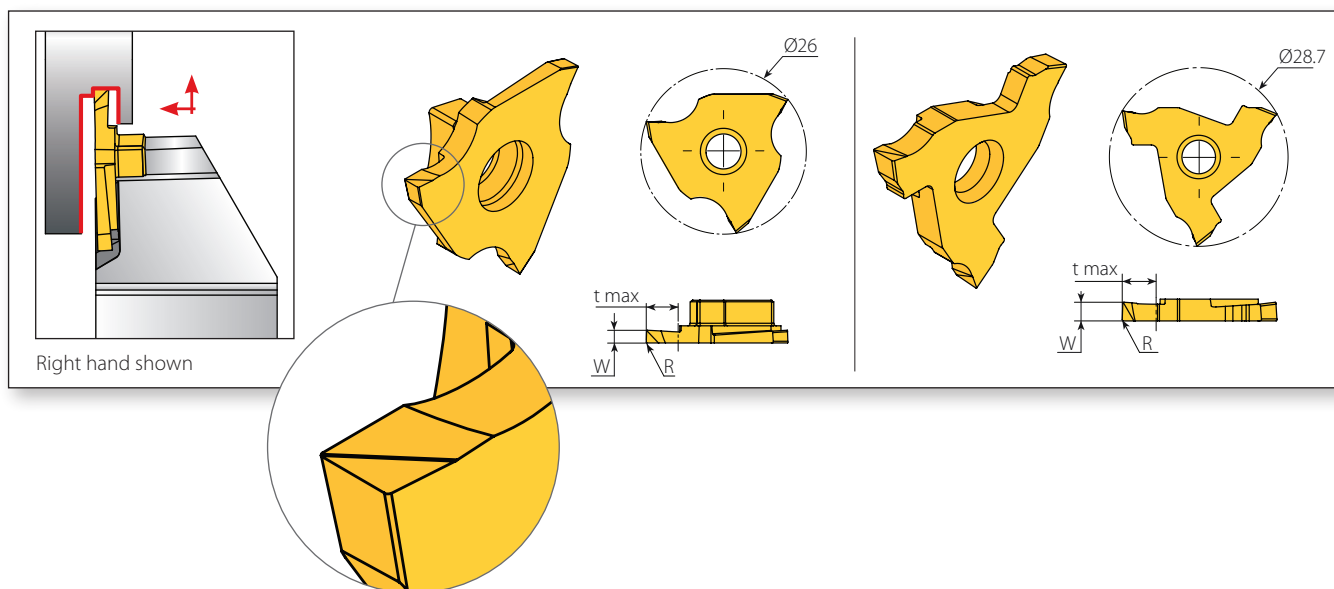

Insert Size	Ordering Code	Dimensions mm			Grade		Toolholder
		W \pm 0.02	R \pm 0.03	t max	VKX	VTX	
26	GVN26R/LT1.0-0.08	1.0	0.08	3.0	◦	•	GVNE...-26, GVNE90...-26
	GVN26R/LT1.5-0.08	1.5	0.08	4.0	◦	•	
	GVN26R/LT2.0-0.1	2.0	0.10	5.0	◦	•	
	GVN26R/LT2.5-0.15	2.5	0.15	5.0	◦	•	
29	GVN29R/LT3.0-0.2	3.0	0.2	6.5	◦	•	GVNE...-29-1, GVNE90...-29-2, GVNI...-29

◼ • In stock ◦ Available upon request

Close to Shoulder Square Grooving

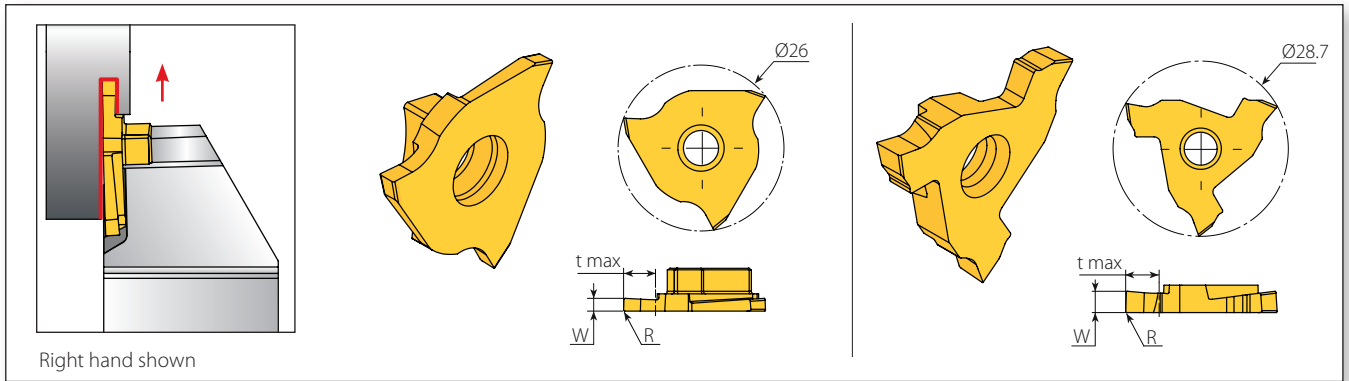

Insert Size	Ordering Code	Dimensions mm			Grade		Toolholder
		W ^{+0.02}	R ^{+0.03}	t max	VKX	VTX	
26	GVN26R/LS0.57-00	0.57	0.00	1.0	•	○	GVNE...-26, GVNE90...-26
	GVN26R/LS0.79-00	0.79	0.00	1.6	•	○	
	GVN26R/LS0.79-0.2	0.79	0.20	1.6	•	○	
	GVN26R S0.8-0.2	0.80	0.20	2.0	•	○	
	GVN26R/LS0.87-00	0.87	0.00	2.0	•	○	
	GVN26R/LS0.97-00	0.97	0.00	2.0	•	○	
	GVN26R/LS1.0-0.1	1.00	0.10	2.0	•	○	
	GVN26R/LS1.07-00	1.07	0.00	2.0	•	○	
	GVN26R/LS1.2-00	1.20	0.00	2.0	•	○	
	GVN26R/LS1.24-00	1.24	0.00	2.0	•	○	
	GVN26R/LS1.4-00	1.40	0.00	2.0	•	○	
	GVN26R/LS1.44-00	1.44	0.00	2.0	•	○	
	GVN26R/LS1.5-0.1	1.50	0.10	3.0	•	○	
	GVN26R/LS1.5-0.2	1.50	0.20	5.0	•	○	
	GVN26R/LS1.58-0.2	1.58	0.20	3.0	•	○	
	GVN26R/LS1.6-00	1.60	0.00	3.0	•	○	
	GVN26R/LS1.7-0.1	1.70	0.10	3.0	•	○	
	GVN26R/LS1.74-00	1.74	0.00	3.0	•	○	
	GVN26R/LS2.0-00	2.00	0.00	3.0	•	○	
	GVN26R/LS2.0-0.1	2.00	0.10	3.0	•	○	
	GVN26RS2.0-0.2	2.00	0.20	5.0	•	•	
GVN26LS2.0-0.2	2.00	0.20	5.0	•	○		
GVN26R/LS2.22-0.15	2.22	0.15	5.0	•	○		
GVN26R/LS2.39-0.15	2.39	0.15	5.0	•	○		
GVN26R/LS2.47-0.2	2.47	0.20	5.0	•	○		
29	GVN29R/LS2.38-0.1	2.38	0.10	6.5	•	○	GVNE...-29-1, GVNE90...-29-1, GVNI...-29
	GVN29R/LS2.5-0.1	2.50	0.10	6.5	•	○	
	GVN29R/LS2.7-0.1	2.70	0.10	6.5	•	○	
	GVN29R/LS3.0-0.2	3.00	0.20	6.5	•	○	
	GVN29R/LS3.17-0.2	3.17	0.20	6.5	•	○	
	GVN29R/LS3.5-0.2	3.50	0.20	6.5	•	•	
	GVN29R/LS4.0-0.4	4.00	0.40	6.5	•	•	
GVN29R/LS5.0-0.4	5.00	0.40	6.5	•	•	GVNE...-29-2, GVNE90...-29-2, GVNI...-29	

• In stock ○ Available upon request

Close to Shoulder Round Grooving

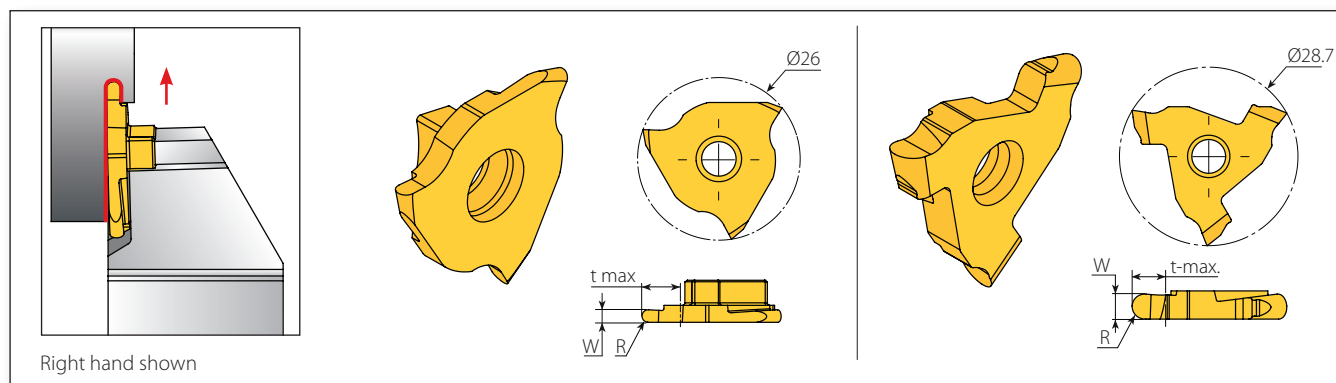

Insert Size	Ordering Code	Dimensions mm			Grade		Toolholder
		$W_{\pm 0.02}$	$R_{\pm 0.03}$	t max	VKX	VTX	
26	GVN26R/LR0.5-0.25	0.50	0.25	1.0	•	◦	GVNE...-26, GVNE90...-26
	GVN26R/LR0.79-0.39	0.79	0.39	1.6	•	◦	
	GVN26R/LR1.0-0.5	1.00	0.50	2.0	•	◦	
	GVN26RR1.2-0.6	1.20	0.60	2.0	•	•	
	GVN26RL1.2-0.6	1.20	0.60	2.0	•	◦	
	GVN26R/LR1.5-0.75	1.50	0.75	5.0	•	◦	
	GVN26R/LR1.6-0.8	1.60	0.80	3.0	•	◦	
	GVN26R/LR2.0-1.0	2.00	1.00	3.0	•	◦	
GVN26R/LR2.39-1.19	2.39	1.19	5.0	•	◦		
29	GVN29R/LR2.38-1.19	2.38	1.19	6.5	•	◦	GVNE...-29-1, GVNE90...-29-1, GVNI...-29
	GVN29R/LR2.5-1.25	2.50	1.25	6.5	•	◦	
	GVN29R/LR3.0-1.5	3.00	1.50	6.5	•	◦	
	GVN29R/LR3.17-1.59	3.17	1.59	6.5	•	◦	
	GVN29R/LR4.0-2.0	4.00	2.00	6.5	•	•	

• In stock ◦ Available upon request

Close to Shoulder Parting Off

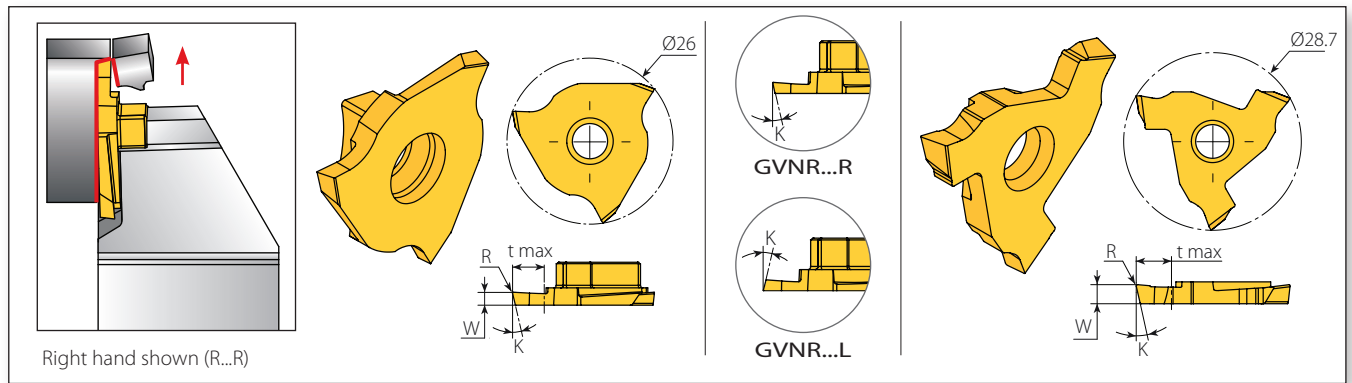

Insert Size	Ordering Code	Dimensions mm				Grade		Toolholder
		IC	RH/LH	W ^{±0.02}	R ^{±0.03}	t max	K°	
26	GVN26RP0.5-0.05-06R	0.5	0.05	1.0	6	●	○	GVNE...-26, GVNE90...-26
	GVN26RP0.5-0.05-06L	0.5	0.05	1.0	6	○	○	
	GVN26LP0.5-0.05-06R	0.5	0.05	1.0	6	○	○	
	GVN26LP0.5-0.05-06L	0.5	0.05	1.0	6	●	○	
	GVN26RP0.5-0.05-15R	0.5	0.05	1.0	15	●		
	GVN26RP0.5-0.05-15L	0.5	0.05	1.0	15	●	○	
	GVN26LP0.5-0.05-15R	0.5	0.05	1.0	15	●	○	
	GVN26LP0.5-0.05-15L	0.5	0.05	1.0	15	●	○	
	GVN26R P1.2-0.08-05R	1.2	0.08	1.0	5	●	○	
	GVN26RP1.4-0.05-06R	1.4	0.05	5.0	6	●	○	
	GVN26RP1.4-0.05-06L	1.4	0.05	5.0	6	○	○	
	GVN26LP1.4-0.05-06R	1.4	0.05	5.0	6	○	○	
	GVN26LP1.4-0.05-06L	1.4	0.05	5.0	6	●	○	
	GVN26RP1.4-0.05-15R	1.4	0.05	5.0	15	●	○	
	GVN26RP1.4-0.05-15L	1.4	0.05	5.0	15	●	○	
	GVN26LP1.4-0.05-15R	1.4	0.05	5.0	15	●	○	
	GVN26LP1.4-0.05-15L	1.4	0.05	5.0	15	●	○	
	GVN26RP2.0-0.1-06R	2.0	0.10	5.0	6	●	●	
	GVN26RP2.0-0.1-06L	2.0	0.10	5.0	6	●	○	
	GVN26LP2.0-0.1-06R	2.0	0.10	5.0	6	○	○	
	GVN26LP2.0-0.1-06L	2.0	0.10	5.0	6	●	○	
	GVN26RP2.0-0.1-15R	2.0	0.10	5.0	15	●	○	
	GVN26RP2.0-0.1-15L	2.0	0.10	5.0	15	●	○	
	GVN26LP2.0-0.1-15R	2.0	0.10	5.0	15	●	○	
GVN26LP2.0-0.1-15L	2.0	0.10	5.0	15	●	○		
29	GVN29RP2.5-0.2-06R	2.5	0.20	6.5	6	●	●	GVNE...-29-1, GVNE90...-29-1, GVNI...-29
	GVN29RP2.5-0.2-06L	2.5	0.20	6.5	6	○	○	
	GVN29LP2.5-0.2-06R	2.5	0.20	6.5	6	○	○	
	GVN29LP2.5-0.2-06L	2.5	0.20	6.5	6	●	●	
	GVN29RP2.5-0.2-15R	2.5	0.20	6.5	15	●	●	
	GVN29RP2.5-0.2-15L	2.5	0.20	6.5	15	○	○	
	GVN29LP2.5-0.2-15R	2.5	0.20	6.5	15	○	○	
	GVN29LP2.5-0.2-15L	2.5	0.20	6.5	15	●	●	
	GVN29RP3.0-0.2-06R	3.0	0.20	6.5	6	●	●	
	GVN29RP3.0-0.2-06L	3.0	0.20	6.5	6	○	○	
	GVN29LP3.0-0.2-06R	3.0	0.20	6.5	6	○	○	
	GVN29LP3.0-0.2-06L	3.0	0.20	6.5	6	●	●	
	GVN29RP3.0-0.2-15R	3.0	0.20	6.5	15	●	●	
	GVN29RP3.0-0.2-15L	3.0	0.20	6.5	15	○	○	
	GVN29LP3.0-0.2-15R	3.0	0.20	6.5	15	○	○	
	GVN29LP3.0-0.2-15L	3.0	0.20	6.5	15	●	●	

● In stock ○ Available upon request

Square Grooving (GV29)

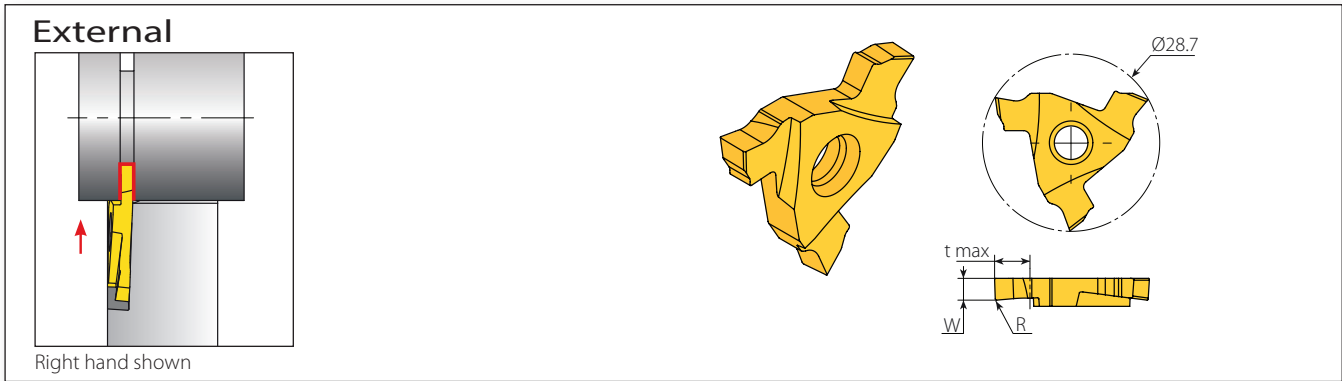

Insert Size	Ordering Code	Dimensions mm			Grade		Toolholder
		W ^{±0.02}	R ^{±0.03}	t max	VKX	VTX	
29	GV29R/LS2.38-0.1	2.38	0.10	6.5	•	•	GVE...-29-1, GVE90...-2901, GVI...-29
	GV29R/LS2.5-0.1	2.50	0.10	6.5	•	•	
	GV29R/LS2.7-0.1	2.70	0.10	6.5	•	•	
	GV29R/LS3.0-0.2	3.00	0.20	6.5	•	•	
	GV29R S3.0-0.4	3.00	0.40	6.5	•	•	GVE...-29-2, GVE90...-29-2, GVI...-29, GVNE...-29-2, GVNE90...-29-2, GVNI...-29
	GV29R/LS3.17-0.2	3.17	0.20	6.5	•	•	
	GV29R/LS3.5-0.2	3.50	0.20	6.5	•	•	
	GV29R/LS4.0-0.4	4.00	0.40	6.5	•	•	
GV29R/LS5.0-0.4	5.00	0.40	6.5	•	•		

• In stock ◦ Available upon request

Round Grooving (GV29)

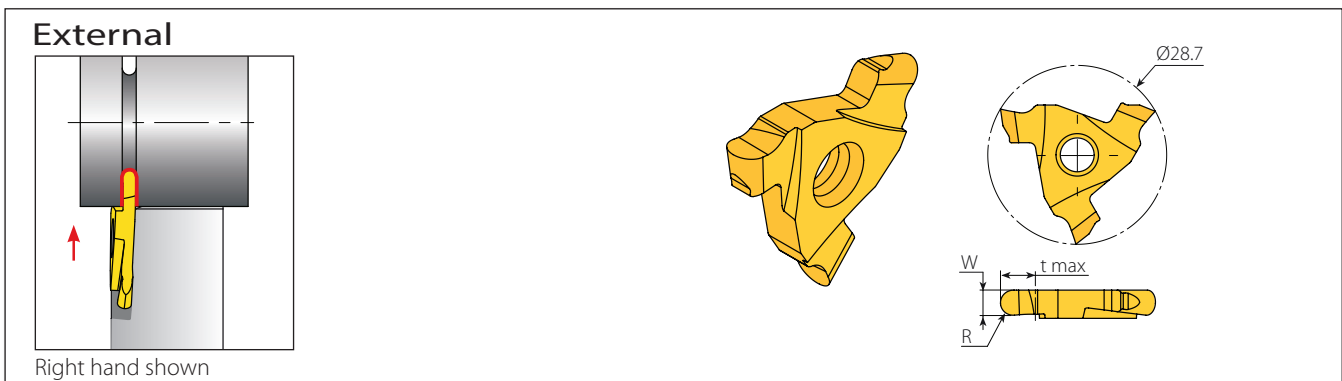

Insert Size	Ordering Code	Dimensions mm			Grade		Toolholder
		W ^{±0.02}	R ^{±0.03}	t max	VKX	VTX	
29	GV29R/LR2.38-1.19	2.38	1.19	6.5	•	•	GVE...-29-1, GVE90...-2901, GVI...-29
	GV29R/LR2.5-1.25	2.50	1.25	6.5	•	•	
	GV29R/LR3.0-1.5	3.00	1.50	6.5	•	•	
	GV29R/LR3.17-1.59	3.17	1.59	6.5	•	•	GVE...-29-2, GVE90...-29-2, GVI...-29, GVNE...-29-2, GVNE90...-29-2, GVNI...-29
	GV29R/LR4.0-2.0	4.00	2.00	6.5	•	•	

• In stock ◦ Available upon request

Groovical External Holders

Close to Shoulder External Toolholders.....	12
Close to Shoulder External Toolholders 90°.....	13
External Toolholders 90° (GV29).....	14
External Toolholders (GV29).....	14
Close to Shoulder Internal Toolholders (GVN29).....	15
Internal Toolholders (GV29).....	15

Holders - Ordering Code System

GVN	E	R	20	-	29	-	1
1	2	3	4		5		6

1 - Insert Type	2 - External Type	3 - RH or LH	4 - Shank Size
GV - Groovical Neutral GVN - Groovical Close to Shoulder	E - External E90 - External 90°	R - RH L - LH	10, 12, 16, 20, 25, 32, 40 mm

5 - Insert Size	6 - Insert Width (for GVN29 & GV29)
26 29	1 - 2.5 - 3.5mm 2 - 3.6 - 5.5mm

GVN29 & GV29 Internal Holders

GVN	I	R	25	-	29
1	2	3	4		5

1 - Insert Type	2 - Type	3 - RH or LH	4 - Shank Size	5 - Insert Size
GV - Groovical Neutral GVN - Groovical Close to Shoulder	I - Internal	R - RH L - LH	25, 32 mm	29

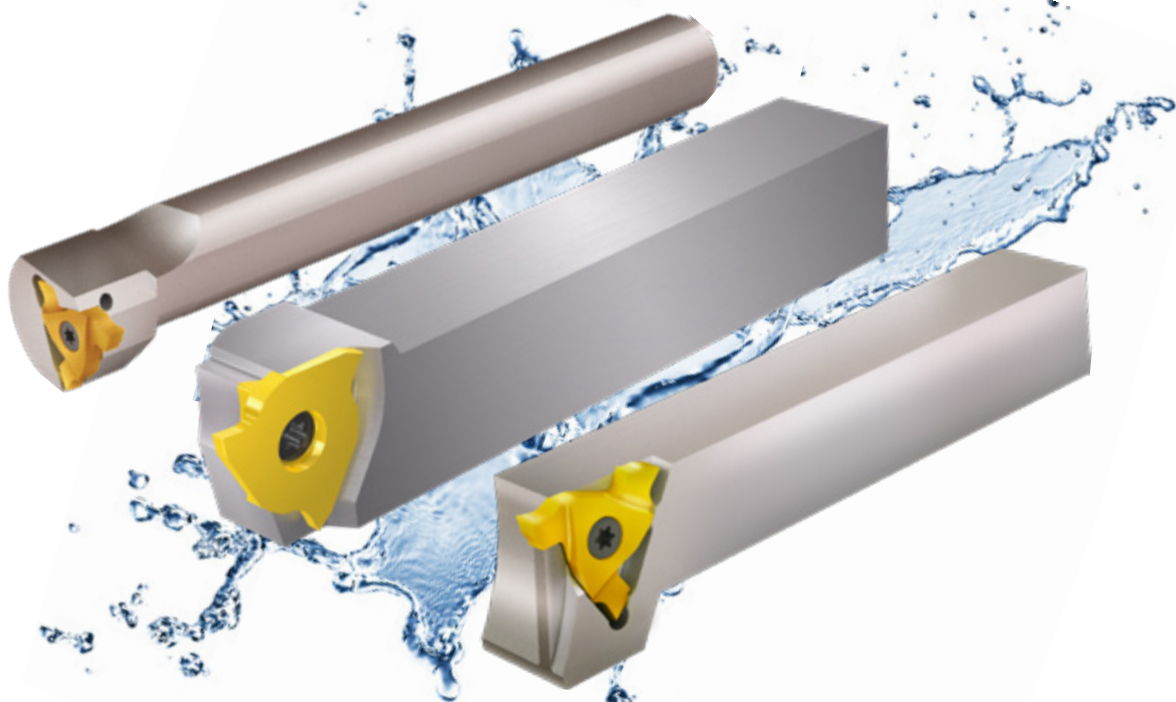

Close to Shoulder External Toolholders

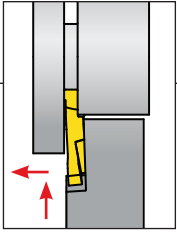

Right hand shown

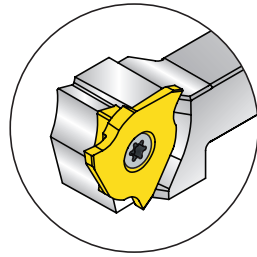

GVN26

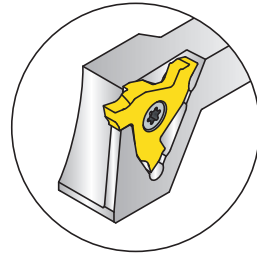
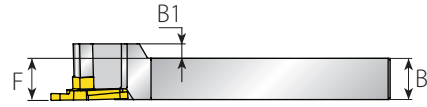
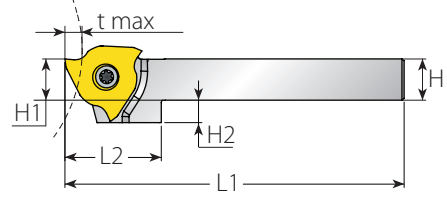

GVN29

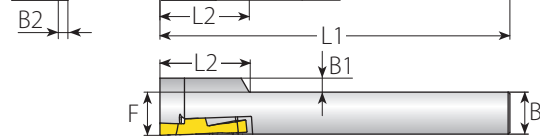
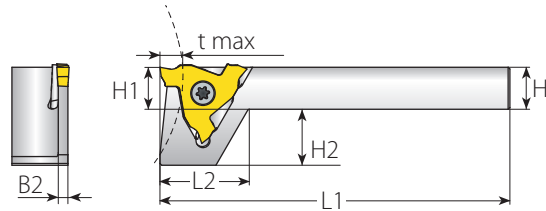

Insert Size	Ordering Code	Dimensions mm									Spare Parts			
		RH/LH	H=B	L1	H1	L2	H2	F	B1	B2	t max/D max	Insert Screw*	Torx Key	
26	GVNER/L10-26		10	125	10	28.0	8.5	10.2	6.2			See page 4	SGM5	L20IP
	GVNER/L12-26		12	125	12	28.0	6.5	12.2	4.2					
	GVNER/L16-26		16	125	16	28.0	2.5	16.2	-	-				
	GVNER/L20-26		20	125	20	28.0	-	20.2	-	-				
	GVNER/L25-26		25	150	25	28.0	-	25.2	-	-				
29	GVNER/L12-29-1		12	100	12	25.5	16	12.5	4	1.75				
	GVNER/L12-29-2		12	100	12	25.5	16	12.5	4	2.75				
	GVNER/L16-29-1		16	125	16	23.2	12	16.5	-	1.75				
	GVNER/L16-29-2		16	125	16	23.2	12	16.5	-	2.75				
	GVNER/L20-29-1		20	125	20	20.9	8	20.5	-	1.75				
	GVNER/L20-29-2		20	125	20	20.9	8	20.5	-	2.75				
	GVNER/L25-29-1		25	150	25	18.0	3	25.5	-	1.75				
GVNER/L25-29-2		25	150	25	18.0	3	25.5	-	2.75					

* Tightening Torque 4.5 Nm

Close to Shoulder External Toolholders 90°

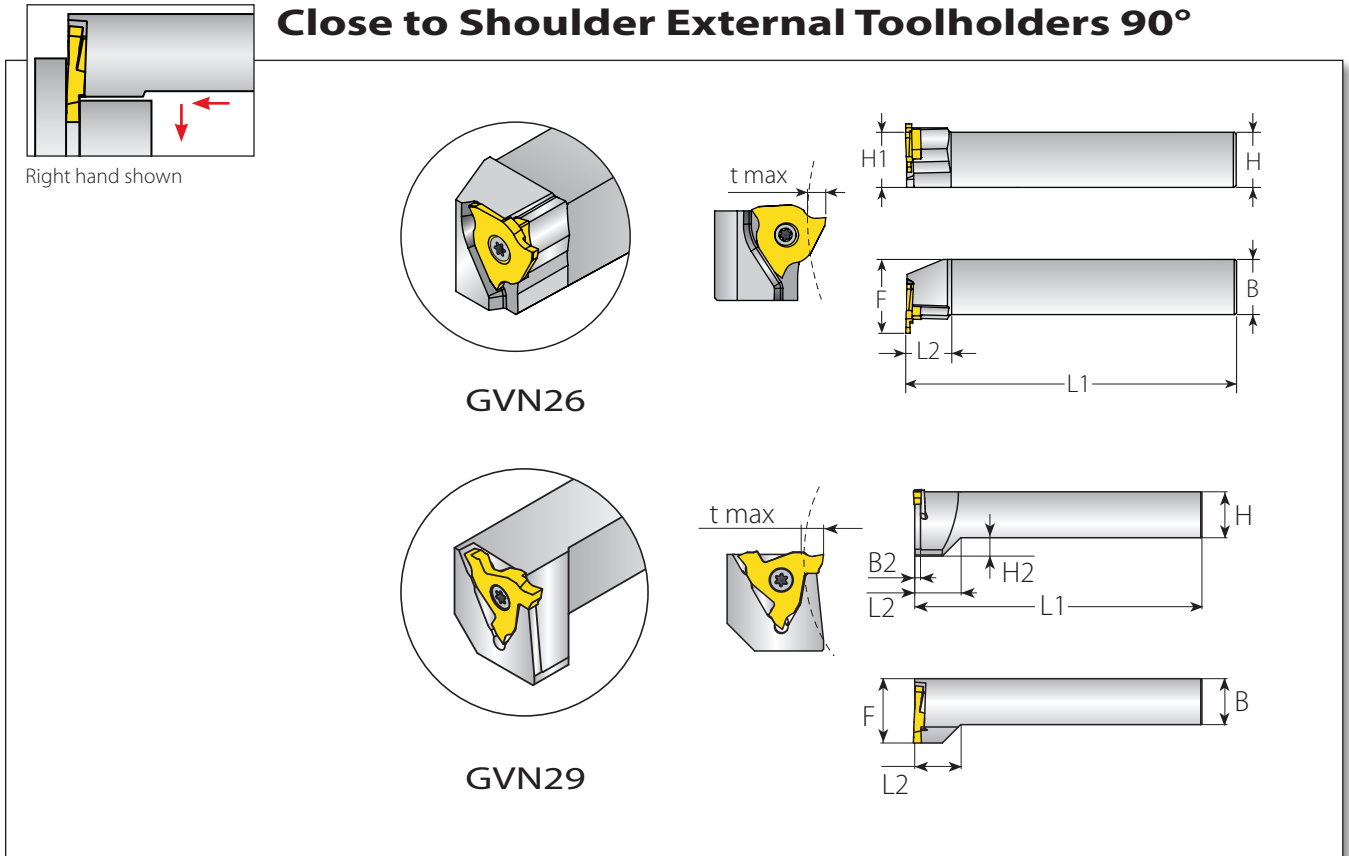

Insert Size	Ordering Code	Dimensions mm								Spare Parts		
		RH/LH	H=B	L1	H1	L2	B2	H2	F	t max/D max	Insert Screw*	Torx Key
26	GVNE90R/L20-26		20	125	20	20.0	-	-	28.5	See page 4	SGM5	L20IP
	GVNE90R/L25-26		25	150	25	20.0	-	-	33.5			
29	GVNE90R/L20-29-1		20	125	20	20.2	1.75	8	28.0			
	GVNE90R/L20-29-2		20	125	20	20.2	2.75	8	28.0			
	GVNE90R/L25-29-1		25	150	25	25.0	1.75	3	33.0			
	GVNE90R/L25-29-2		25	150	25	25.0	2.75	3	33.0			

* Tightening Torque 4.5 Nm

- For **LH90°** work applications use **LH toolholder** with **RH insert** and vice versa.
- For **LH Internal** work applications use **LH toolholder** with **RH insert** and vice versa.

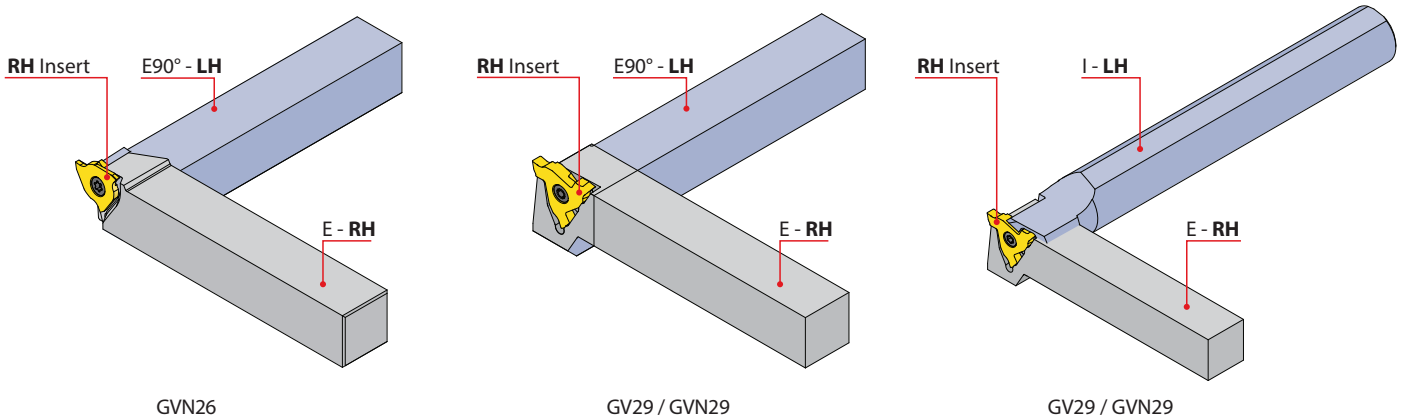

External Toolholders (GV29)

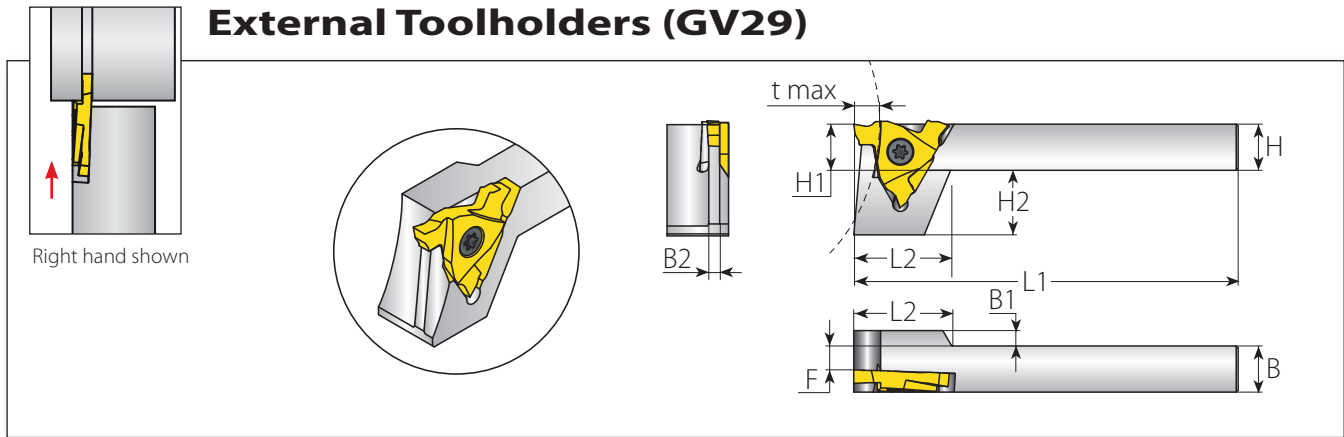

Insert Size	Ordering Code	Dimensions mm									Spare Parts		
		RH/LH	H=B	L1	H1	L2	H2	F	B1	B2	t max/D max	Insert Screw*	Torx Key
29	GVER/L12-29-1		12	100	12	25.5	16	7.2	4	1.75	See page 4	SGM5	L20IP
	GVER/L12-29-2		12	100	12	25.5	16	6.2	4	2.75			
	GVER/L16-29-1		16	125	16	23.2	12	11.2	-	1.75			
	GVER/L16-29-2		16	125	16	23.2	12	10.2	-	2.75			
	GVER/L20-29-1		20	125	20	20.9	8	15.2	-	1.75			
	GVER/L20-29-2		20	125	20	20.9	8	14.2	-	2.75			
	GVER/L25-29-1		25	150	25	18	3	20.2	-	1.75			
	GVER/L25-29-2		25	150	25	18	3	19.2	-	2.75			

* Tightening Torque 4.5 Nm

External Toolholders 90° (GV29)

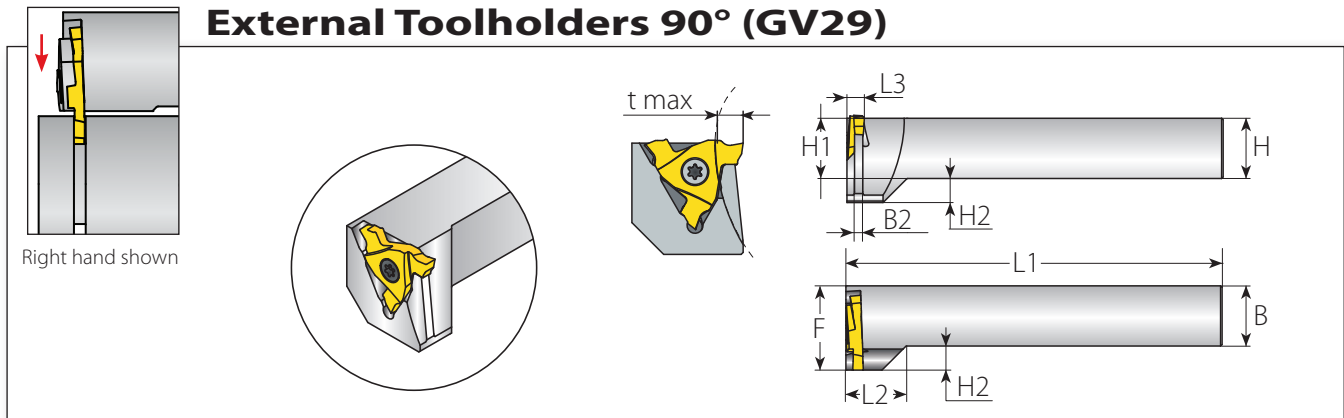

Insert Size	Ordering Code	Dimensions mm									Spare Parts		
		RH/LH	H=B	L1	H1	L2	H2	F	L3	B2	t max/D max	Insert Screw*	Torx Key
29	GVE90R/L20-29-1		20	125	20	20.2	8	28	4.8	1.75	See page 4	SGM5	L20IP
	GVE90R/L20-29-2		20	125	20	20.2	8	28	5.8	2.75			
	GVE90R/L25-29-1		25	150	25	25.2	8	33	4.8	1.75			
	GVE90R/L25-29-2		25	150	25	25.2	8	33	5.8	2.75			

* Tightening Torque 4.5 Nm

Close to Shoulder Internal Toolholders with Coolant

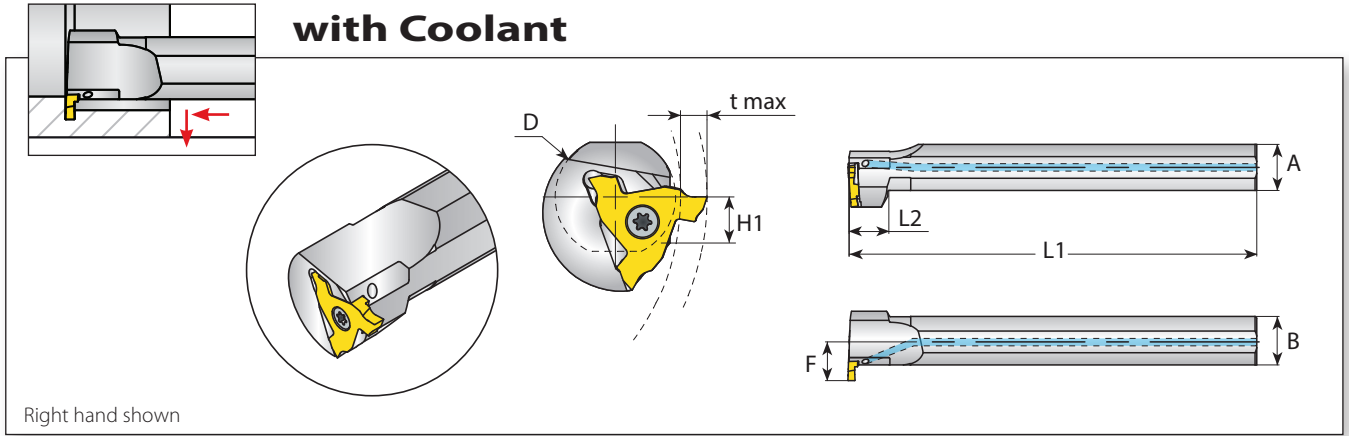

Insert Size	Ordering Code	Dimensions mm								Spare Parts	
		RH/LH	D	L1	L2	A	B	H1	F	t max/D max	Insert Screw*
29	GVNIR/L25-29	25	200	19	22.6	23.8	11.3	19.0	See page 4	SGM5	L20IP
	GVNIR/L32-29	32	250	19	29.0	30.5	14.5	22.2			

* Tightening Torque 4.5 Nm

Internal Toolholders (GV29) with Coolant

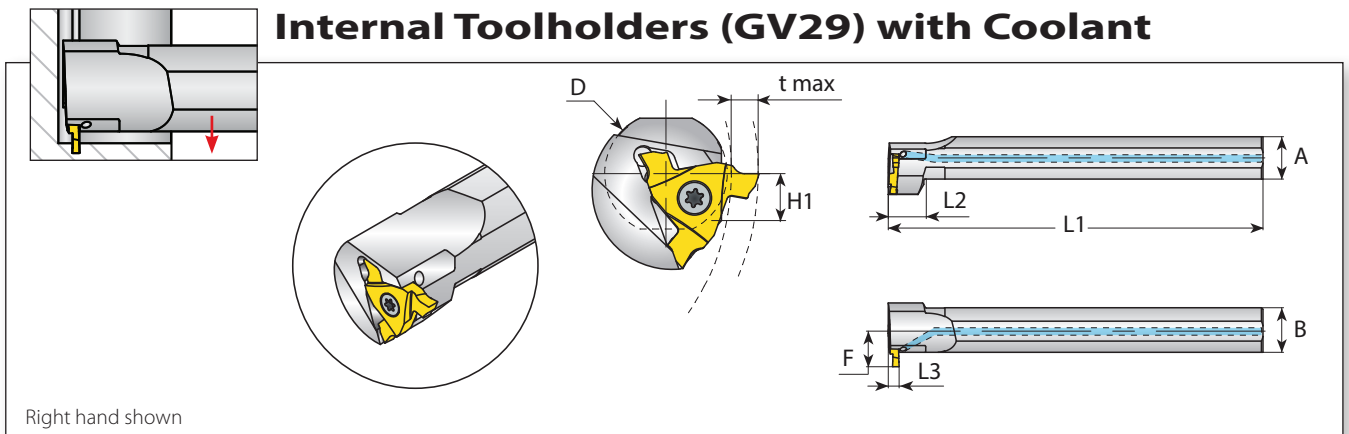

Insert Size	Ordering Code	Dimensions mm									Spare Parts	
		RH/LH	D	L1	L2	L3	A	B	H1	F	t max/D max	Insert Screw*
29	GVR25-29	25	200	19	5.8	22.6	23.8	11.3	19.0	See page 4	SGM5	L20IP
	GVR32-29	32	250	19	5.8	29.0	30.5	14.5	22.2			

* Tightening Torque 4.5 Nm

GrooVical

Precise Grooving
& Turning Applications



GROOVEX

Innovative Grooving & Turning Solutions